

Tiger Universal Beam Clamp Model No. BCU

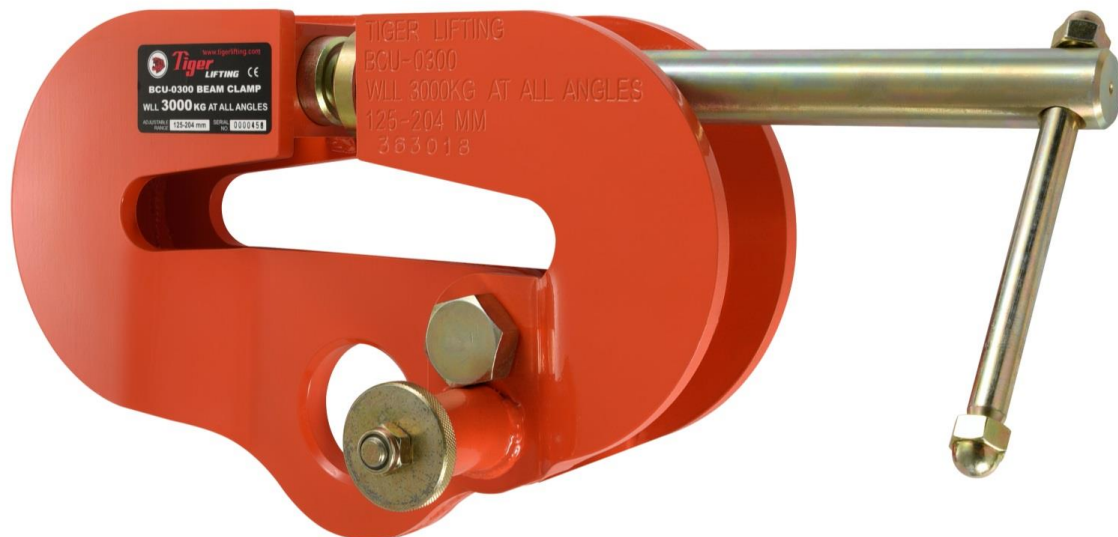

Main Features

- Full rated capacity at any lifting angle
- 3.0t and 5.0t capacities available, 10t available soon
- Quick and versatile rigging point for hoisting equipment
- Low headroom design
- Highly flexible – for lifting, pulling or as a semi-permanent anchor point
- Designed for both vertical and side loading applications - can be loaded at any angle
- Suitable for pulling and lifting at angles across the beam
- Designed to accommodate a wide range of beam widths
- Multidirectional adjusting screw spindle ensures a high clamping force to beam web
- Operating temperature of -50°C to +50°C
- 4:1 factor of safety
- Complies with ASME B30.20 and EN13155 :2003+A2 :2009

Warning: Do not exceed working load limits or use this equipment for lifting flat plate sections

Certification:

Each unit comes fully certified with a test certificate or an EC Declaration of Conformity stating compliance with the essential health and safety requirements of the Machinery Directive 2006/42/EC.

The Tiger Universal Beam Clamp Model No BCU has been designed not only for vertical use, but also for side load applications, where conventional clamps are not suitable. This clamp is highly flexible in application and can be used for lifting, pulling or as a semi-permanent anchor point. It can be loaded at any angle and eliminates the use of spreader beams in various lifting operations.

Technical Data

Product Code	Capacity (tonne)	Dimensions (mm)											Net Weight (kg)
		A	B	C	D	E	F	G	H	J	K	L	
BCU-0300	3.0	387	60	70	63	32	235	100	25	28	20	125-204	15.5
BCU-0500	5.0	524	70	74	72	32	270	120	25	38	24	125-305	27.0
BCU-1000	10.0	524	70	75	82	32	278	120	25	38	25	125-305	TBA

E=maximum beam web thickness

H=maximum beam flange thickness

Technical Drawing

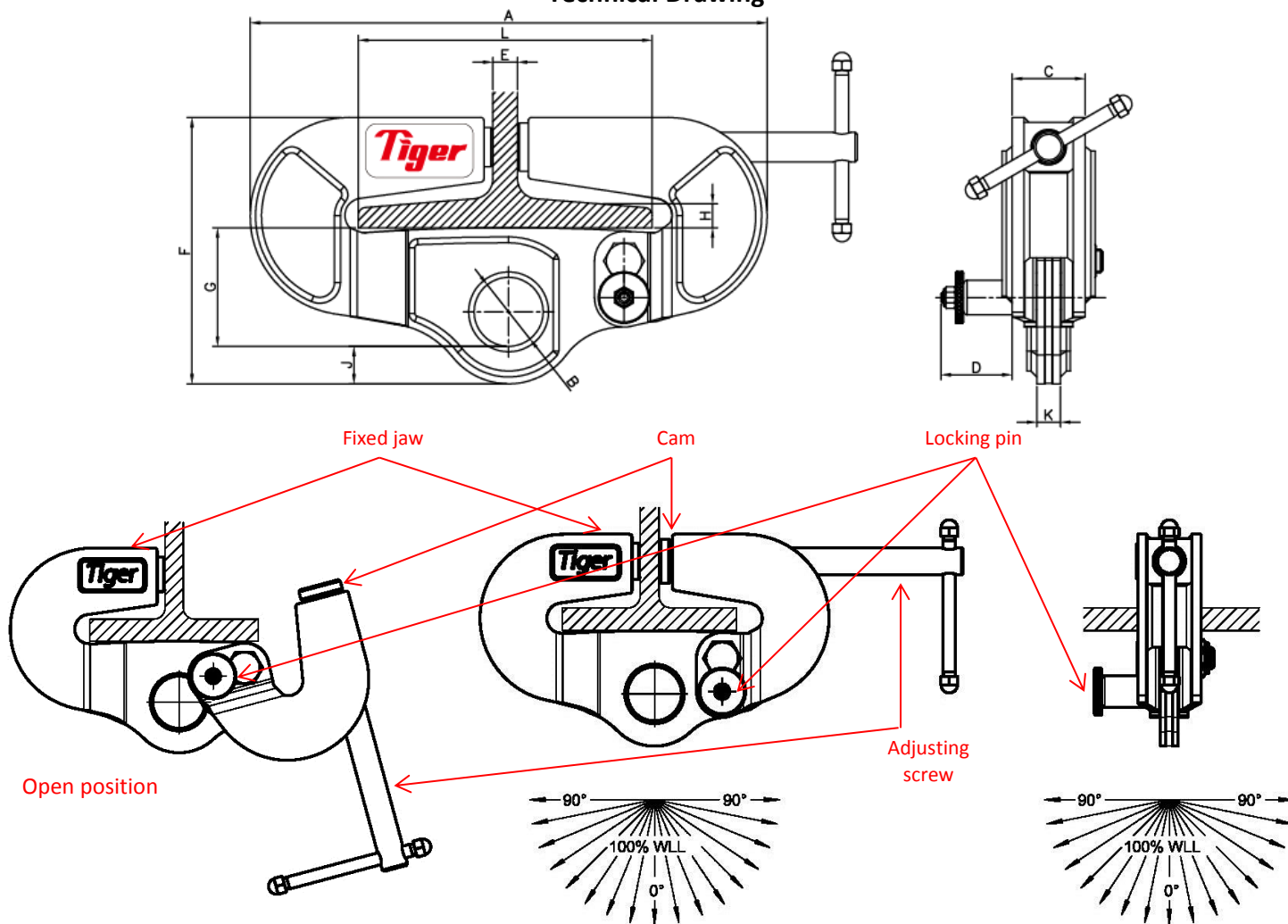

Due to our policy of continual product development, dimensions, weights and specifications may change without prior notice. Please check with your Tiger sales team when ordering.