

Tiger Brake Hand Winch

Model No. BHW



BHW



BHW - Corrosion Protected

Main Features

- The original brake hand winch
- High quality multi-purpose winch
- Automatic load-actuated brake can hold the load in any position
- Compact, light-weight and rugged construction
- Gears and brakes fully covered to prevent dust, dirt and rain contamination
- Heat treated gears
- Very low operator effort required for easy operation
- Dual handle pinion shaft option available on all models, allows handle to be fitted on both sides.
- Universal mounting plate
- Available as 800lb, 1200lb, 1800lb and 2600lb models.
- For cable and strap
- Finished in high quality powder coat paint offering excellent corrosion protection
- Fully corrosion protected versions available
- Noiseless 1200lb model available
- 3D Drawings available on full range for project planning
- Operating temperature -40°C to +80°C (temperature range of -60°C to +80°C available as an option)

The Tiger Brake Winch is a high quality multi-purpose winch used for a wide variety of lifting and hoisting applications. The automatic brake ensures the load remains suspended when the crank is released and avoids unchecked descent of the load; there is no freewheeling making the hand winch extremely safe to operate. All the mechanical components are enclosed for protection against dust, dirt and rain contamination. This equipment has a lifting capacity ranging from 800lbs to 2600lbs. The BHW is compact and lightweight yet rugged and durable. These units meet and exceed all the requirements within BS EN 13157: 2004+A1:2009.

Certification:

Each unit comes fully certified with a test certificate or an EC Declaration of Conformity stating compliance with the essential health and safety requirements of the Machinery Directive 2006/42/EC.

Our innovation, your safety

Noiseless 1200lb Model:

This model is equipped with a unique quiet brake design that is virtually silent and fully automatic. Best suited to those locations where quiet is required, such as schools, hospitals and theatres.



Corrosion Protection Option:

This model is protected using our unique formulation giving unprecedented long term reliability and superior corrosion resistance and protection in the most severe conditions. The coating provides excellent friction protection and has been proven to be effective through at least 1000 hours of the ASTM B 117 Salt Spray Test. The coating gives the properties of stainless steel without the cost implications.



Dual Handle Option:

Our BHW range can be modified with a new style pinion shaft that allows the handle to be fitted on either or both sides of the winch; this has been designed for areas with difficult access or situations when the conventional right handed winch handle isn't suitable.

For BHW winches with a dual handled pinion shaft, the BHW-0800 (800lb) and BHW-1200 (1200lb) models are supplied with two handles, as the fittings for each side are not the same. The BHW-1800 (1800lb) and BHW-2600 (2600lb) models come with one handle that fits on either side. If a handle is required to be fitted on both sides of either the 1800lb or 2600lb models, please ask us for more details. The dual handle pinion shaft for the noiseless version (BHW-1200N) is not generally available from stock but may be available as an option – please contact us if this is your preferred design.



Technical Data

Product Code	Pulling Capacity (lbs/kg)	Lifting Capacity (lbs/kg)			Gear Ratio	Hub Diameter (mm)	Handle Length (mm)	Unit Weight (kg)	Cable Diameter (mm/inch)	Cable Storage Cap. (m)	Strap Storage Cap. (m)
		1 st Layer	Mid Layer	Last Layer							
BHW-0800	800/360	800/360	560/254	400/180	4.1:1	ø40	160	3.0	ø4/ø5/32	36	9.1
BHW-1200	1200/550	1200/550	864/392	600/275	4.1:1	ø50	210	3.5	ø5/ø3/16	23	8.5
BHW-1200-N	1200/550	1200/550	864/392	600/275	4.1:1	ø50	210	4.0	ø5/ø3/16	23	8.5
BHW-1800	1800/800	1800/800	1239/562	900/400	5:1	ø70	320	8.0	ø6/ø1/4	24	14.1
BHW-2600	2600/1180	2600/1180	1861/844	1300/590	10:1	ø82	320	10.5	ø8/ø5/16	18	10.6

Winch Straps (for pulling only)

Product Code	Description	Width (mm)	Thickness (mm)	Breaking load (kg)	Available for
TG-48	6 meters with safety hook	48	1.2	2068.5	BHW-800 & BHW-1200
TG-54	9 meters with safety hook	54	1.4	2864.0	BHW-1800
TG-60	9 meters with safety hook	60	1.7	4136.0	BHW-2600



Wire Rope

Product Code	Description	Diameter (mm)	Breaking load (kg)	Available for
WWR-04-30	30 meters with safety hook	4	1270	BHW-0800
WWR-05-20	20 meters with safety hook	5	2000	BHW-1200
WWR-06-22	22 meters with safety hook	6	3000	BHW-1800
WWR-08-16	16 meters with safety hook	8	4500	BHW-2600

Technical Drawings

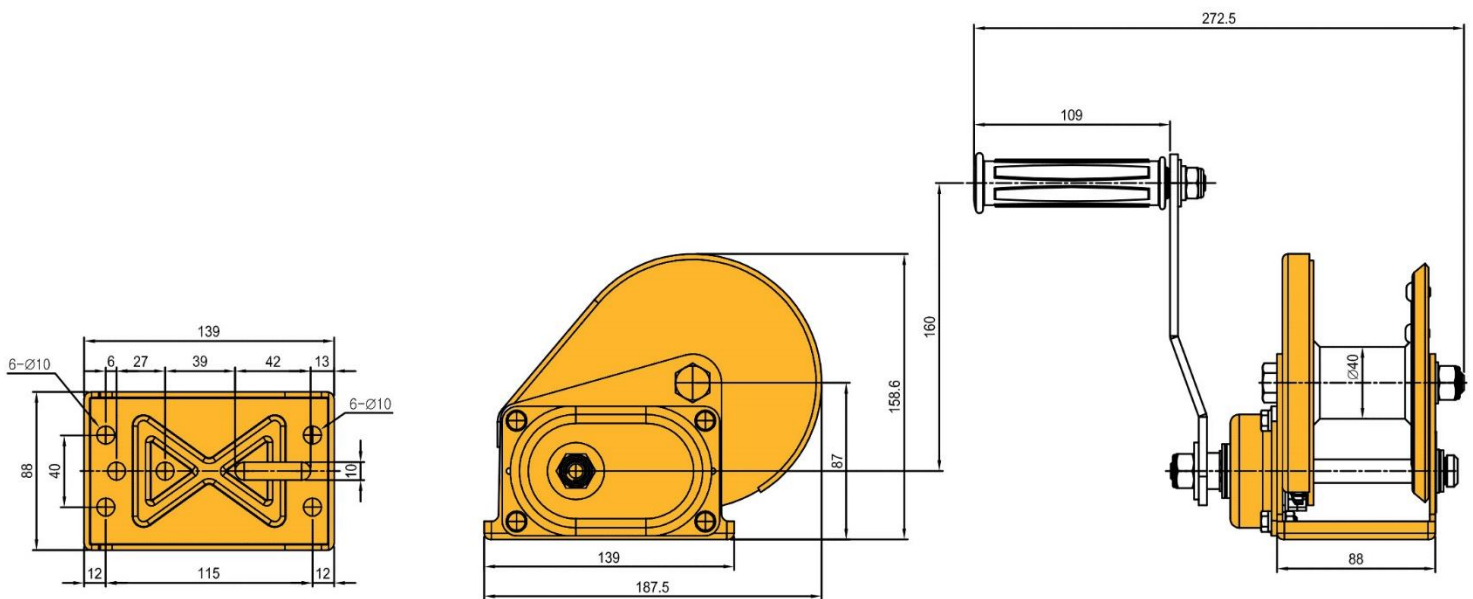

BHW-800

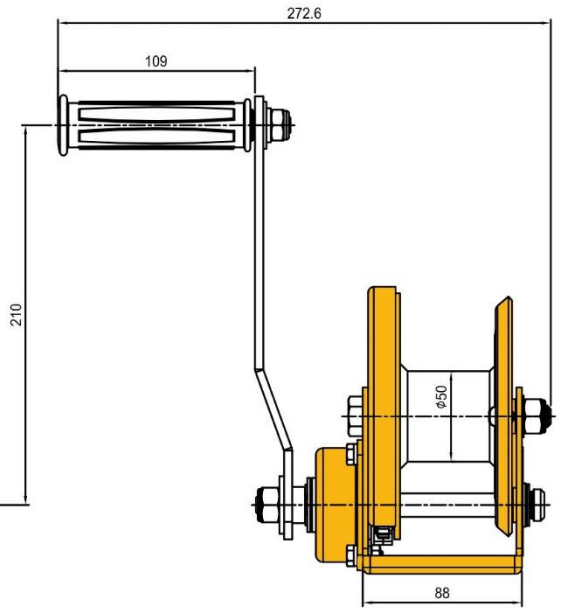
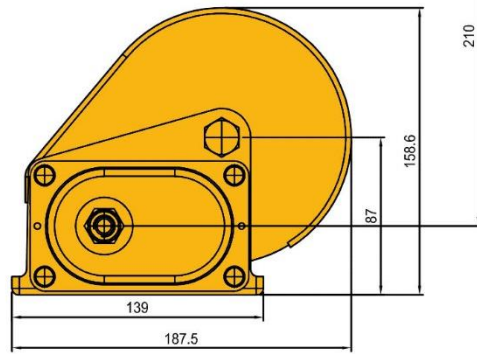
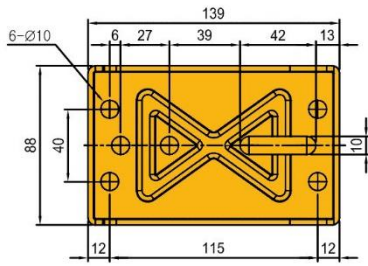

BHW-1200

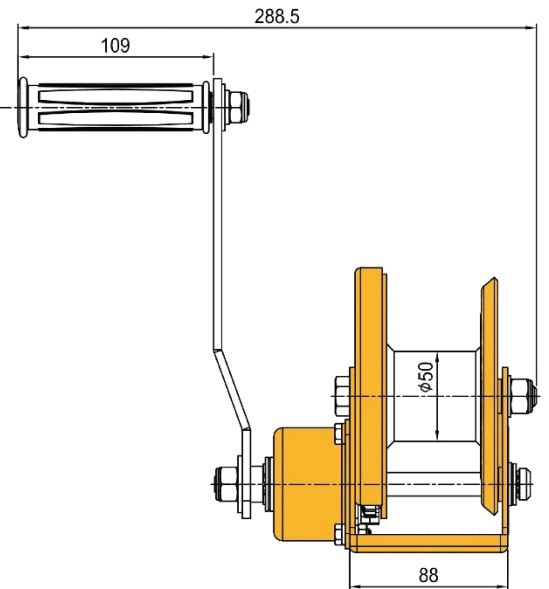
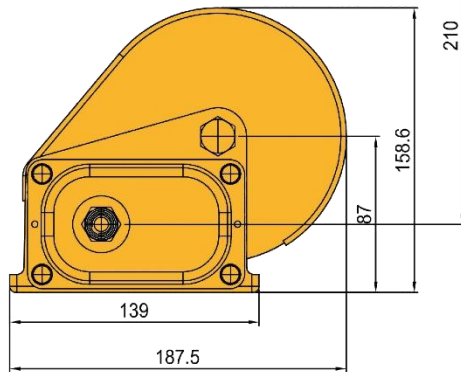
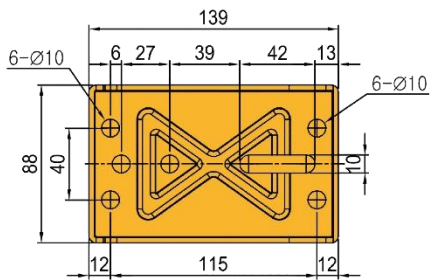

BHW-1200-N

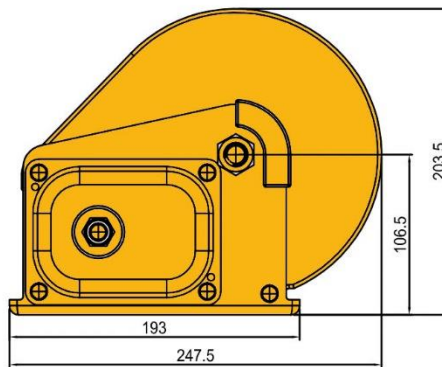
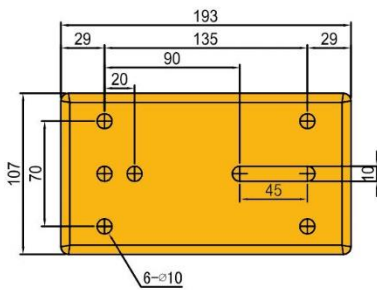

BHW-1800

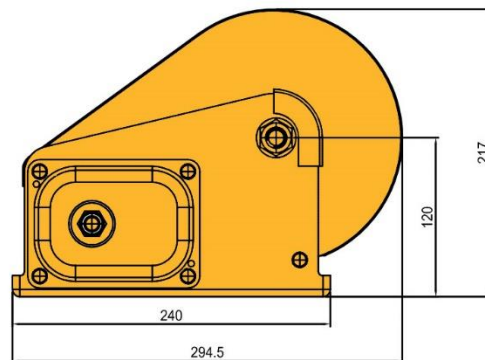
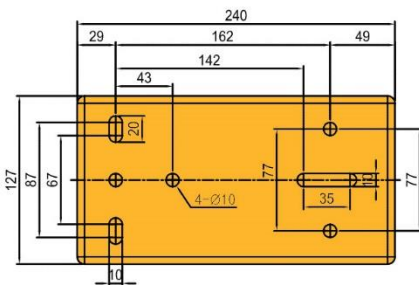
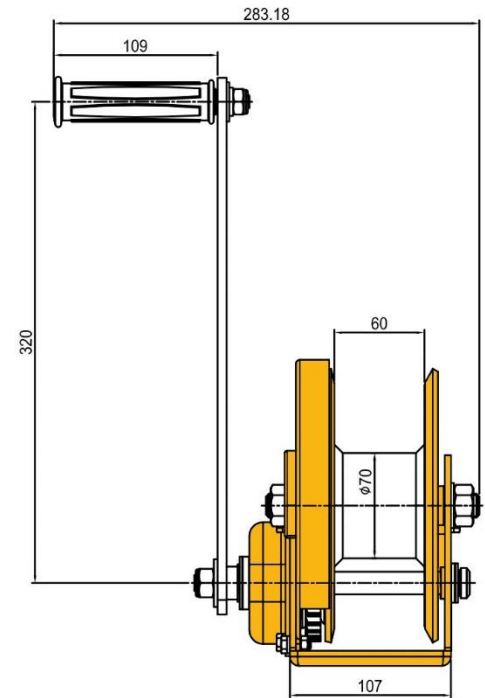

BHW-2600

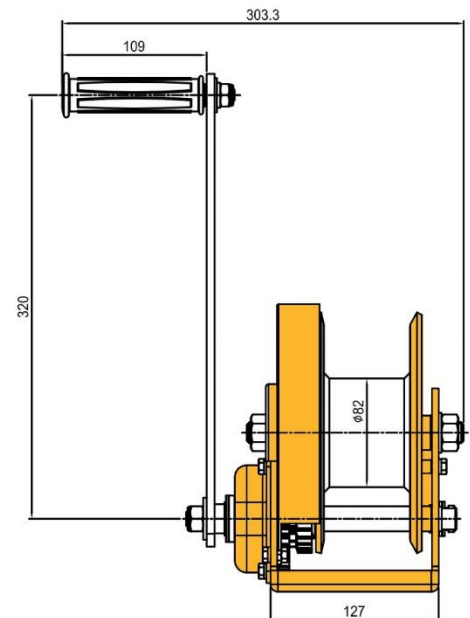

Due to our policy of continual product development, dimensions, weights and specifications may change without prior notice. Please check with your Tiger sales team when ordering.

Bespoke designs available on request – contact info@tigerlifting.com for more information.

Our innovation, your safety