

# RUD-ICE-Eye bolt

(for low temperatures up to -60°C/-76°F)



## Safety instructions

This safety instruction/declaration has to be kept on file for the whole lifetime of the product.

Translation of the original safety instruction



**RUD Ketten**  
**Rieger & Dietz GmbH u. Co. KG**  
 73428 Aalen  
 Tel. +49 7361 504-1370  
 Fax +49 7361 504-1171  
 sling@rud.com  
 www.rud.com

RUD-Art.-Nr.: 8504889-EN / 07.019

# RUD-ICE-Eye bolt - rigid

(for low temperatures up to -60°C/-76°F)

## IRS-LT (-60°C/-76°F)



Simple inspection, administration and documentation of inspection obligatory tools and supplies for work plus components.

**EC-Declaration of conformity**

According to the EC-Machinery Directive 2006/42/EC, annex II A and amendments

Manufacturer: **RUD Ketten Rieger & Dietz GmbH u. Co. KG**  
 Friedensinsel  
 73432 Aalen

We hereby declare that the equipment sold by us because of its design and construction, as mentioned below, corresponds to the appropriate, basic requirements of safety and health of the corresponding EC-Machinery Directive 2006/42/EC as well as to the below mentioned harmonized and national norms as well as technical specifications. In case of any modification of the equipment, not being agreed upon with us, this declaration becomes invalid.

**Product name:** ICE-Eye bolt \_\_\_\_\_  
 IRS-LT \_\_\_\_\_

The following harmonized norms were applied:

<u>DIN EN ISO 12100 : 2011-03</u>	<u>EN ISO 3266 : 2010</u>
_____	_____
_____	_____
_____	_____

The following national norms and technical specifications were applied:

<u>BGR 500, KAP2.8 : 2008-04</u>	_____
_____	_____
_____	_____
_____	_____

Authorized person for the configuration of the declaration documents:  
 Michael Betzler, RUD Ketten, 73432 Aalen

Aalen, den 20.10.2016 Dr.-Ing. Arne Kriegsmann, (Prokurist/QMB) *Arne Kriegsmann*  
 Name, function and signature of the responsible person

**EG-Konformitätserklärung**

entsprechend der EG-Maschinenrichtlinie 2006/42/EG, Anhang II A und ihren Änderungen

Hersteller: **RUD Ketten Rieger & Dietz GmbH u. Co. KG**  
 Friedensinsel  
 73432 Aalen

Hiermit erklären wir, dass die nachfolgend bezeichnete Maschine aufgrund ihrer Konzipierung und Bauart, sowie in der von uns in Verkehr gebrachten Ausführung, den grundlegenden Sicherheits- und Gesundheitsanforderungen der EG-Maschinenrichtlinie 2006/42/EG sowie den unten aufgeführten harmonisierten und nationalen Normen sowie technischen Spezifikationen entspricht. Bei einer nicht mit uns abgestimmten Änderung der Maschine verliert diese Erklärung ihre Gültigkeit.

**Produktbezeichnung:** ICE-Ringschraube \_\_\_\_\_  
 IRS-LT \_\_\_\_\_

Folgende harmonisierten Normen wurden angewandt:

<u>DIN EN ISO 12100 : 2011-03</u>	<u>EN ISO 3266 : 2010</u>
_____	_____
_____	_____
_____	_____

Folgende nationalen Normen und technische Spezifikationen wurden außerdem angewandt:

<u>BGR 500, KAP2.8 : 2008-04</u>	_____
_____	_____
_____	_____
_____	_____

Für die Zusammenstellung der Konformitätsdokumentation bevollmächtigte Person:  
 Michael Betzler, RUD Ketten, 73432 Aalen

Aalen, den 20.10.2016 Dr.-Ing. Arne Kriegsmann, (Prokurist/QMB) *Arne Kriegsmann*  
 Name, Funktion und Unterschrift Verantwortlicher

## User instructions

1. Reference should be made to German Standards accord. BGR 500, chapter 2.8 (DGUV 100-500) or other country specific statutory regulations and inspections are to be carried out by competent persons only.

2. ICE-Eye bolts IRS-LT are mainly used as lifting means for permanent installation at equipment's like engines, electrical cabinets, gearboxes ect. for their transportation. For the alternating usage at different to be transported goods like large tools and dies, eye bolts of the next bigger size must be used.

3. Before installing and every use, inspect visually RUD lifting points, paying particular attention to any evidence of corrosion, wear and weld cracks and deformations. Please ensure compatibility of bolt thread and tapped hole.

4. The material construction to which the lifting point will be attached should be of adequate strength to withstand forces during lifting without deformation. The German testing authority BG, recommends the following minimum for bolt lengths:

- 1 x M in steel (minimum quality S235JR [1.0037])
  - 1,25 x M in cast iron (for example GG 25)
  - 2 x M in aluminium
  - 2,5 x M in light alloys with low strength
- (M = diameter of RUD lifting point bolt, for ex. M 20)

When lifting light metals, nonferrous heavy metals and gray cast iron the thread has to be chosen in such a way that the working load limit of the thread corresponds to the requirements of the respective base material.

5. The lifting points must be positioned on the load in such a way that movement is avoided during lifting.

- a.) For single leg lifts, the lifting point should be vertically above the centre of gravity of the load.
- b.) For two leg lifts, the lifting points must be equidistant to/or above the centre of gravity of the load.
- c.) For three and four leg lifts, the lifting points should be arranged symmetrically around the centre of gravity in the same plane.

### 6. Load Symmetry:

Determine the required WLL of the individual RUD lifting point for symmetrical resp. unsymmetrical loading according to the following physical formula context:

$$W_{LL} = \frac{G}{n \times \cos \beta}$$

$W_{LL}$  = working load limit  
 $G$  = load weight (kg)  
 $n$  = number of load bearing legs  
 $\beta$  = angle of inclination of the chain to the vertical

The calculation of load bearing legs is as follows:

	symmetrical	asymmetrical
two leg	2	1
three / four leg	3	1

(see table 1)



### ATTENTION

*Rotation during the transportation must be avoided.*

7. A plane bolt-on surface (ØE) with a perpendicular thread hole must be guaranteed.

The thread must be carried out acc. to DIN 76 (countersink max. 1.05xd).

Tapped holes must be machined deep enough so that the bearing surface of the lifting point will be supported.

8. All fittings connected to the ICE-eyebolt should be free moving. When connecting and disconnecting the lifting means (sling chain) pinches and impacts should be avoided. Damage of the lifting means caused by sharp edges should be avoided as well.

9. To prevent unintended dismounting through shock loading, rotation or vibration, thread locking fluid such as Loctite (depending on the application, please pay attention to the manufacturer's instruction) could be used to secure the bolt, or use form-closed devices. For lifting points which remains on the construction we basically recommend to secure with liquid locking device or tighten with torque.

### 10. Temperature usage capability:

If the RUD-ICE-Eye bolts are to be used in temperatures ranging from 200°C upwards, the WLL has to be reduced accordingly:

- 60° up to 200°C no reduction (-76°F up to 392°F)
  - 200° up to 300°C minus 10 % (392°F up to 572°F)
  - 300° up to 400°C minus 25 % (572°F up to 752°F)
- Temperatures above 400°C (752°F) are not permitted.

11. RUD-Lifting points must not be used under chemical influences such as acids, alkaline solutions and vapours e.g. in pickling baths or hot dip galvanising plants. If this cannot be avoided, please contact the manufacturer indicating the concentration, period of penetration and temperature of use.

12. Make the location of the lifting points more visible by using a colorful contrast marking.

13. After installation, an annual inspection or if necessary even sooner must be carried out by a competent person to guarantee the lingering ability. This is becomes also effective after a damage or a special occurrence.

### Inspection criteria concerning paragraphs 3 and 13:

- Ensure compatibility of bolt thread and tapped hole
- The plane area of the ICE-eye bolt can completely flat down to the work piece.
- The lifting point should be complete.
- The working load limit and manufacturers stamp should be clearly visible.
- Deformation of the component parts such as body, load ring and bolt.
- Mechanical damage, such as notches, particularly in high stress areas.
- Wear should be no more than 10 % of cross sectional diameter.
- Evidence of corrosion.
- Evidence of cracks.
- Damage to the bolt, nut and/or thread.

**A non-adherence to this advice may result damages of persons and materials!**

Thread	Application	M12	M16	M20	M24 7/8"-9UNC	M30	M36	M42	M48
Working Load Limit [kg] axial (WLL) per each ICE-eye bolt		1,000	2,100	3,600	5,400	8,000	12,000	15,700	21,500
Working Load Limit [kg] ≤ 45° per each ICE-eye bolt		700	1,500	2,500	3,750	5,600	8,800	11,000	15,000
Working Load Limit [kg] ≤ 45° screwed in from the side per each ICE-eye bolt		255	525	900	1,350	2,000	2,900	3,950	5,400

Table 1: Working Load Limit in [kg]

Working Load Limits and conditions of use similar to DIN 580 / ISO 3266

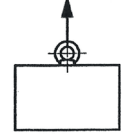
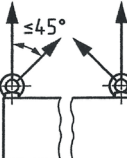
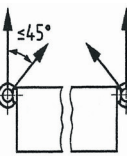
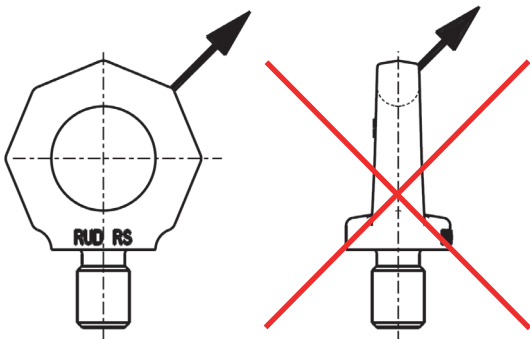

### HINTS FOR WORKING LOAD LIMITS

The in line 2 (chart 1) stated WLL is valid up to an inclination angle of 45° in direction of the ring plane.

The in line 3 (chart 1) stated working load limit is valid for ICE-eye bolts which are screwed in from the side up to an inclination angle of 45° in direction of the ring plane.

**Side pull loading must be avoided (picture 1).**

Pic. 1: Avoid side loading of IRS-LT

Type	WLL [t]	A [mm]	B [mm]	C [mm]	D [mm]	E [mm]	M	T [mm]	weight [kg]	Ref.-No.
IRS-LT (-60°C) M12	1	18	13	12	30	30	M12	41	0,18	7907794***
IRS-LT (-60°C) M16	2.1	24	15	14	35	35	M16	48	0.3	7907795*
IRS-LT (-60°C) M20	3.6	30	17	16	40	40	M20	55	0.45	7907796*
IRS-LT (-60°C) M24	5.4	36	21	20	50	50	M24	70	0.7	7907797*
IRS-LT (-60°C) 7/8"-9UNC	5.4	36	21	20	50	50	M24	70	0,7	7910386*
IRS-LT (-60°C) M30	8	45	26	24	60	60	M30	85	1.6	7907798**
IRS-LT (-60°C) M36	12	54	43	38	90	100	M36	130	6	7907799
IRS-LT (-60°C) M42	15.7	63	43	38	90	100	M42	130	6.2	7907800
IRS-LT (-60°C) M48	21.5	67	43	38	90	100	M48	130	6.4	7907801

Table 2: Dimensioning in [mm]

\* package unit: 10 pieces \*\* package unit: 4 pieces

\*\*\*package unit: 20 pieces

Subject to technical modifications!

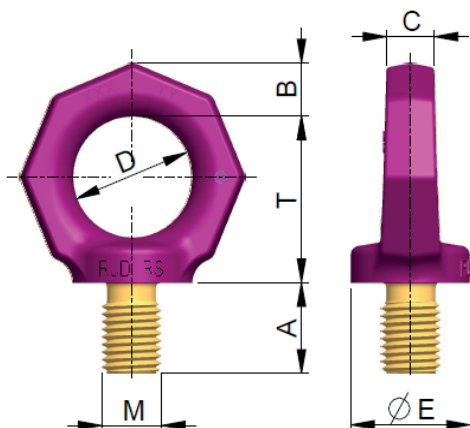

Pic. 2: Technical drawing of IRS-LT

### RUD BLUE-ID SYSTEM RUD BLUE-ID SYSTEM

The IRS-LT will be equipped with a RUD ID-Point® and can clearly be related by the identification number. This number can be determined with the RUD ID-USB-READER (readers) and data can be transferred into the AYE-D.NET-Application.

The application will support your product administration and documentation. For further information please go to the RUD webpage or ask your RUD authorized distributor.